

ABOUT POSSIBILITIES OF OBTAINING FOCUSED BEAMS OF THERMAL NEUTRONS OF RADIONUCLIDE SOURCE

Aripov G.A., Kurbanov B.I., Sulaymanov N.T., Ergashev A.

Institute of Nuclear Physics, Tashkent, Uzbekistan

In the last years significant progress is achieved in development of neutron focusing methods (concentrating neutrons in a given direction and a small area). In this, main attention is given to focusing of neutron beams of reactor, particularly cold neutrons and their applications. [1,2]. However, isotope sources also let obtain intensive neutron beams and solve quite important (tasks) problems (e.g. neutron capture therapy for malignant tumors) [3], and an actual problems is focusing of neutrons.

We developed a device on the basis of californium source of neutrons, allowing to obtain focused (preliminarily) with the aid of respective choice of moderators, reflectors and geometry of their disposition, beam of thermal neutrons. Here of fast neutrons and gamma-rays in the beam are minimized.

The devices for study of thermal neutron capture gamma-rays spectroscopy with radionuclide neutron source which allows one to measure both low energy ($E \leq 2\text{MeV}$) and high energy ($E \geq 2\text{MeV}$) gamma-radiation has been developed on the basis of these researches for analytical applications. Geometry of the device is shown on fig.1. Neutron source of Cf^{252} (1) was located in bismuth filter (2), in which neutrons were effectively slowed down by inelastic processes. Beryllium oxide was taken as moderator (3). The detector was shielded from gamma-radiation of the neutron source and scattered gamma-radiation by bismuth filter (4). A sample holder (6) was also covered by bismuth filter. Lithium filter (7) covering the detector shields it from thermal neutrons. The sample (6) was located near the detector

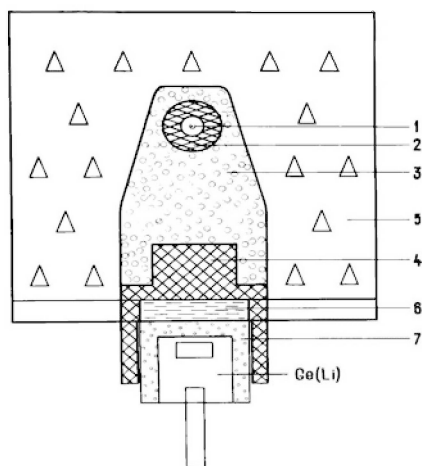

Fig.1. Schematic graph of the device

Low energy spectrum of gamma-radiation of the same sample was measured for comparison of bismuth filter slowing down efficiency with a source in bismuth filter and with source in the paraffin filter at identical shape and geometry. The comparison of these spectra shows what intensively of gamma-rays with 692keV energy from $\text{Ge}^{72}-(n, \gamma)$ reaction is less noticeable with bismuth filter. It means that with bismuth filter the fast neutrons dropping on the detector less than with paraffin filter.

With the aid of the model we developed on the basis of Monte-Carlo method, it is possible to modify a forementioned device and dynamics of output neutrons in wide energy range and analyze ways of optimization of neutron beams of isotope sources with different neutron outputs. Device of preliminary focusing of thermal neutrons can serve as a basis for further focus of

neutrons using micro- and nanocapillary systems. It is known that, capillary systems performed with certain technology can form beam of thermal neutrons increasing its density by more than two orders of magnitude and effectively divert beams up to 20° with length of system 15 sm.

Thus, we can make a conclusion that with using bismuth filter the flux of fast neutrons and background gamma-radiation the reaching the detector is decreased. Neutrons with energy more than 4-5MeV passing through bismuth filter at nonelastic process effectively slow down to the

energy at which light elements are effective moderator material with albedo of neutrons less than albedo of neutrons of the graphite reflector was selected as moderator for the purpose less focus the neutrons and obtain more thermal neutrons falling on the sample. The given choice of the materials and the position geometry of the elements of the device allow us to make a flux of thermal neutrons falling on the sample maximal and flux of fast neutrons and low level background gamma-radiation falling on the detector minimal. It permits us to measure both low energy ($E \leq 2\text{MeV}$) and high energy ($E \geq 2\text{MeV}$) gamma-rays spectra with using radionuclide neutron source

REFERENCES

1. Dabachov S.B. Channeling of neutral particles in micro- and nanocapillars. UFN – 2003. – V.173, №10. – P.1083-1105.
2. Chen-Meyer H.H., Mildner O.F.R., Sharov V.A., Xrao Q.F., Cheng Y.T., Lindstrom R.M., Paul P.Z. Rev. Sci. Instrum. – V.68, №10. – P.3744-3750.
3. Martin R.C., Byme T.E., Miller L.G. “Biomedical neutron research at the Californium user facility for Neutron Science.” J.Radio. Nucl. Chem. – 1998. – V.236. – P510.